

SULZER

Maximizing FCCU Propylene Production at Minimum CAPEX

Gary Martin

gary.martin1@sulzer.com



Technologies That Make a Difference – Now and in the Future



The safe harbor statement under the US private securities litigation reform act 1995

This presentation may contain forward-looking statements, including but not limited to, projections of financial developments, market activities or future performance of products and solutions, containing risks and uncertainties. These forward-looking statements are subject to change based on known or unknown risks and various other factors, which could cause the actual results or performance to differ materially from the statements made herein.

© Sulzer Ltd 2021. All rights reserved.

Current FCCU Direction

- Shift from fuels to petrochemical/chemical production
 - Increased propylene production
 - Historical 5 wt% typical, on fresh feed
 - New units 10-20 wt% but more realistically 10-15 wt%
 - Revamps 7-10 wt% is common



Increased Propylene Recovery Limitations

- Increased difficulty in achieving high propylene recovery
 - High CAPEX and OPEX associated with processing low MW components
 - Increased dry gas
 - Increased C3s
 - Increased C4s



FCCU Gas Plants

Example of Conventional FCCU Gas Plant Configuration

FCCU LPG Recovery – Conventional Design

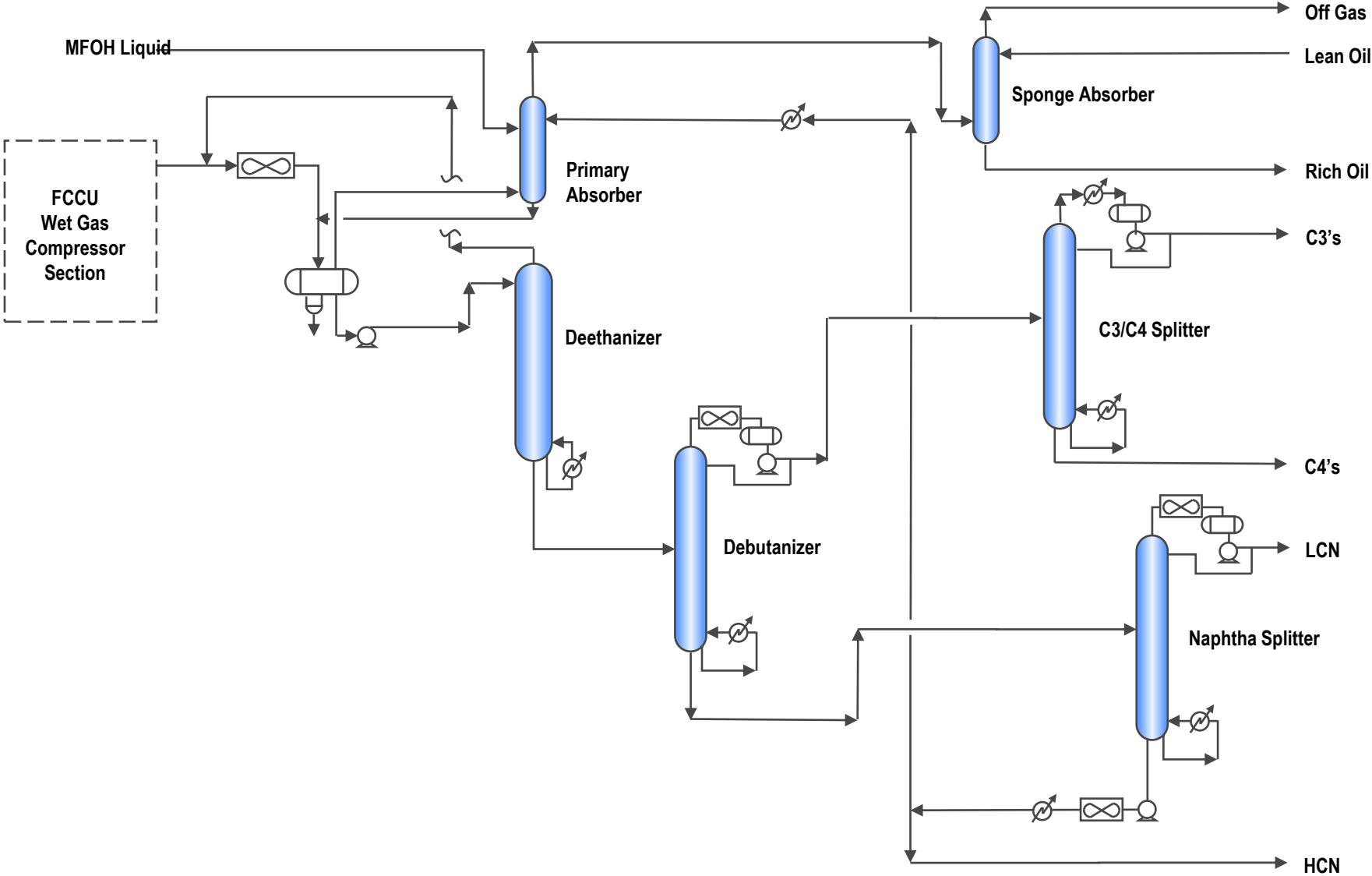

FCCU Gas Plants

Example of DWC FCCU Gas Plant Configurations

DWC FCCU Gas Concentration Unit

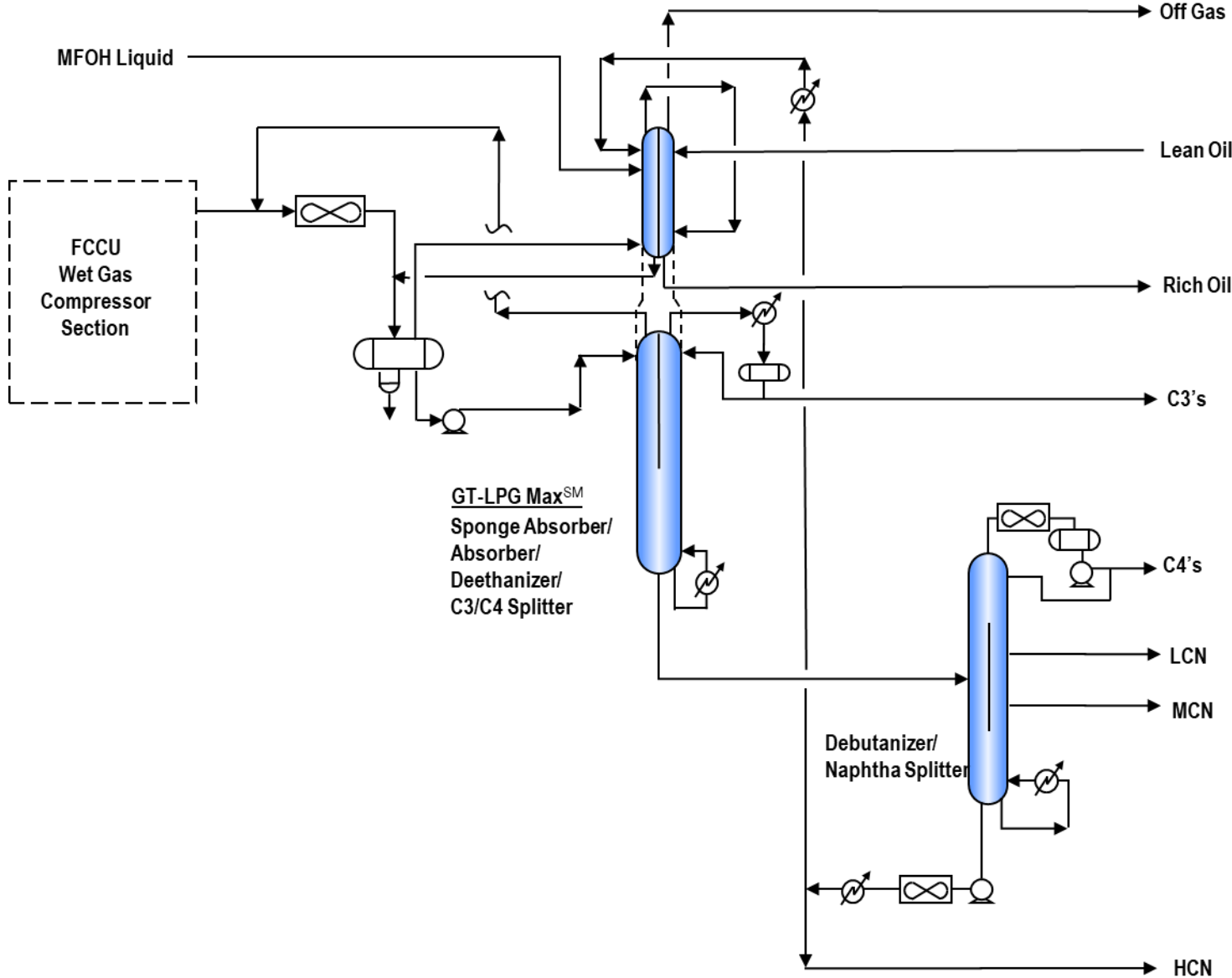

Revamp – DWC FCCU Gas Concentration Unit

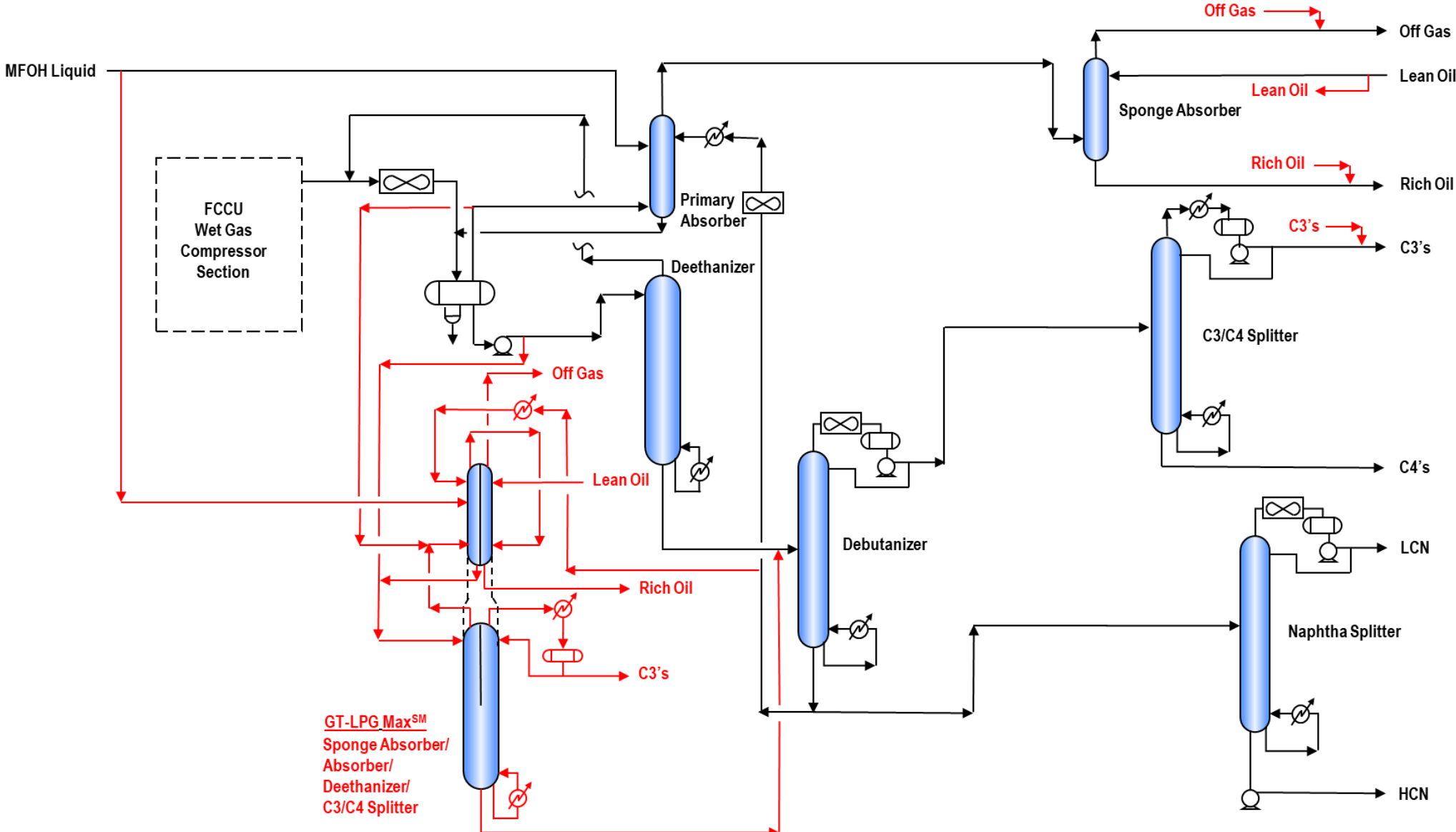

Fundamental Benefits of DWCs

- Lower capital cost
- Smaller plot footprint and weight
- Decreased carbon footprint

DWC FCCU Gas Plant Case Study

DWC FCCU Gas Plant operating in maximum gasoline mode can be designed without using chilled water and produce:

- Greater than 97% propylene recovery
- C3 stream purity of 99% (combined C3's)
- Mixed C4 stream purity of 96.6% (combined C4's)
- C5+ CN stream composition with C4 minus of 1% or less

DWC FCCU Gas Plants

DWC FCCU Gas Plant Technology provides significantly lower CAPEX for:

- Increased gas plant capacity or building new grassroots plants
- Shifting refinery yields to petrochemicals
- Increasing Gasoline Pool Octane while providing low vapor pressure blending components
- Maximizing refinery molecular management to improve margins

SULZER

Maximizing FCCU Propylene Production at Minimum CAPEX

Gary Martin

gary.martin1@sulzer.com

Questions?



Technologies That Make a Difference – Now and in the Future

