



Speed, Accuracy, and End-to-End Control

The Case for Software-driven Networks

Christian Uremovic

Director, Software and Automation Solutions, Infinera

Chris Aspell

Director of Strategy Roadmap and Innovation,
Liberty Global



Digital Transformation Cloudification and Virtualization

Networks are ever growing, getting complex
Increased multi-vendor interoperability requirements

We cannot keep up
with the present mode of operation

Network automation is critical
Speed, accuracy, and better end-to-end control

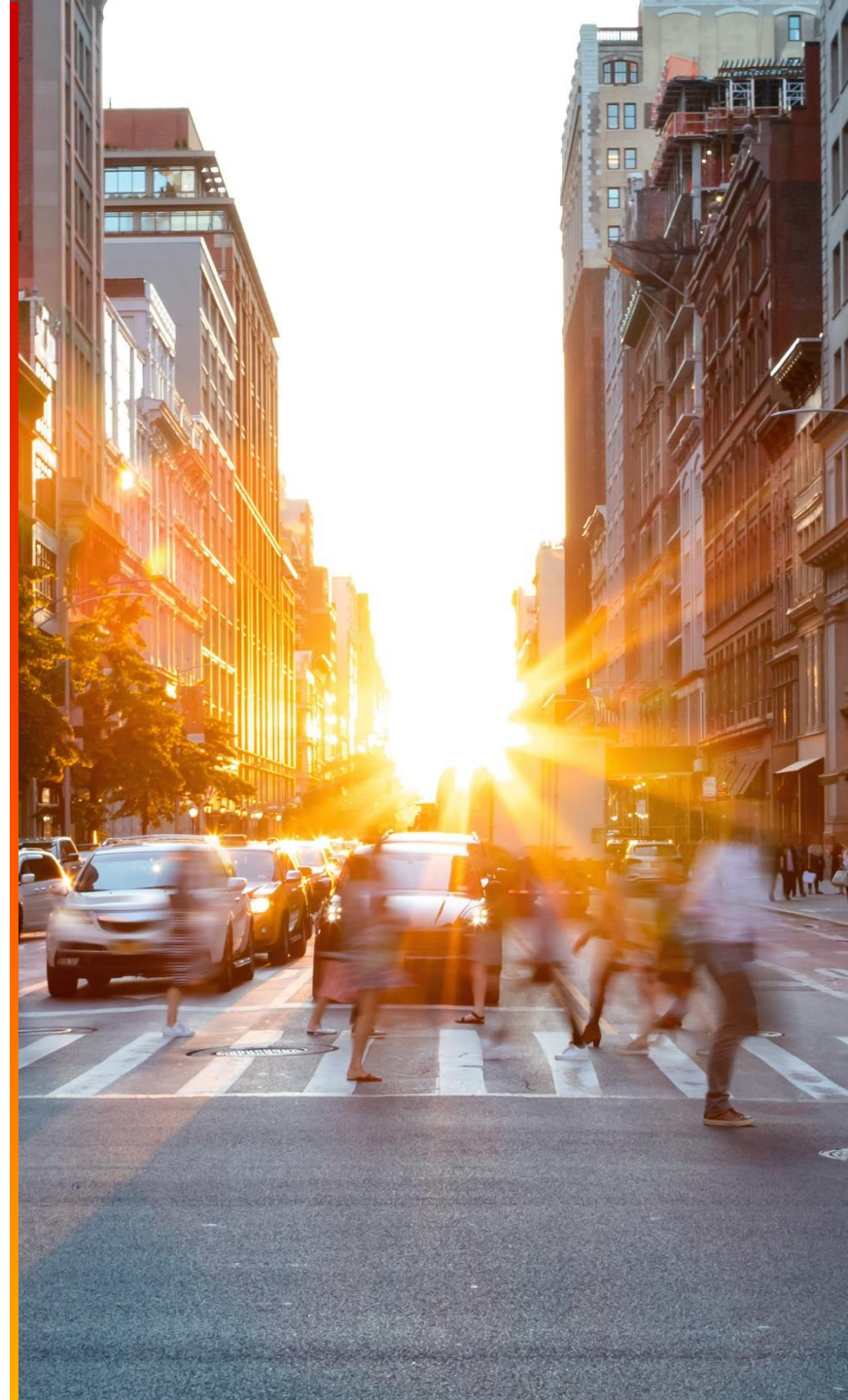

What is Automation Exactly?

Methodology in which software

automatically configures, provisions, manages, and tests network devices to **improve efficiency, reduce human error,** and **reduce operating expenses**

- Network automation tools support functions including:
 - Basic network mapping and device discovery
 - Complex workflows
 - » Network configuration management
 - » Provisioning of network resources
 - Enablement of new service types
 - Improving time to market (speed)
 - Improving accuracy

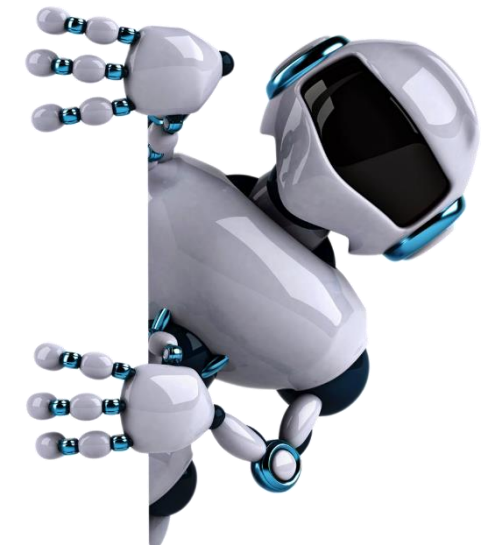

Operating the network more effectively

Automation Drivers and Applications

Drivers

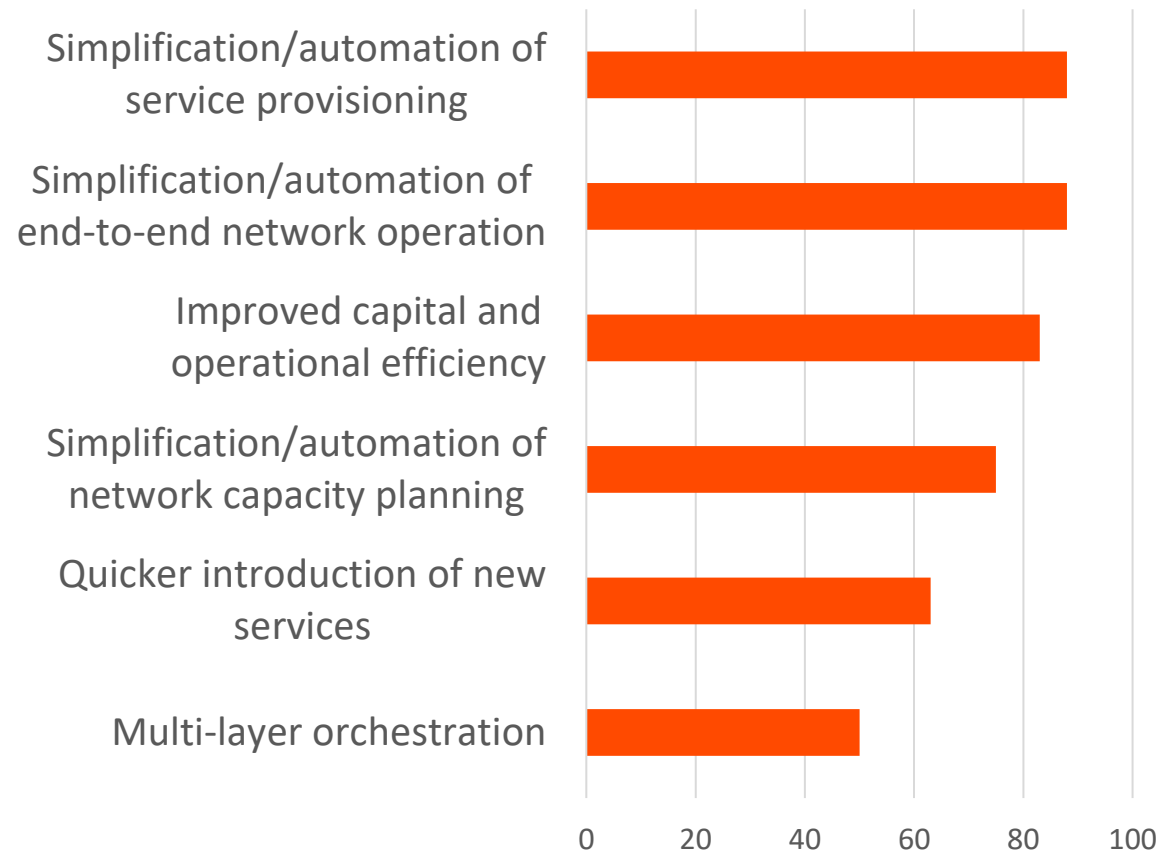

Top Applications

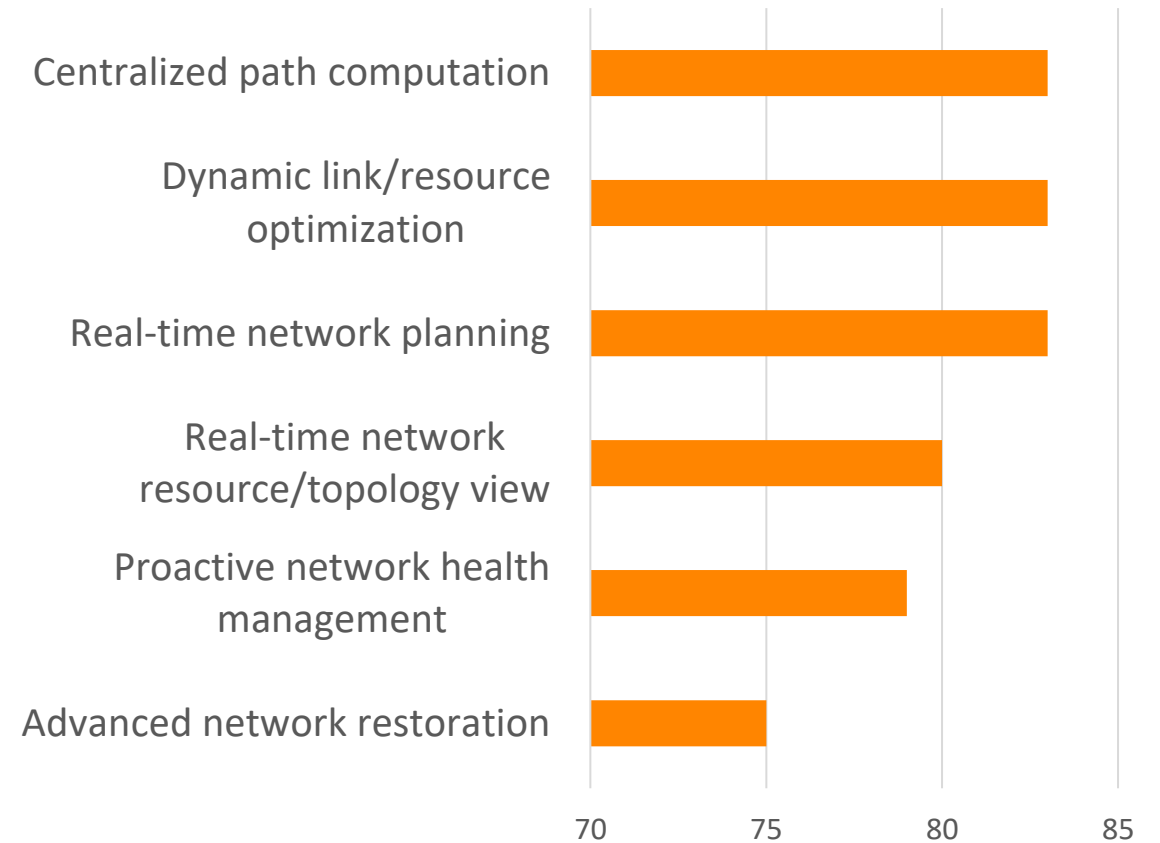

Source: IHS Markit Optical Network Strategies survey, Nov 2019

Hype Cycle of Networking 2019

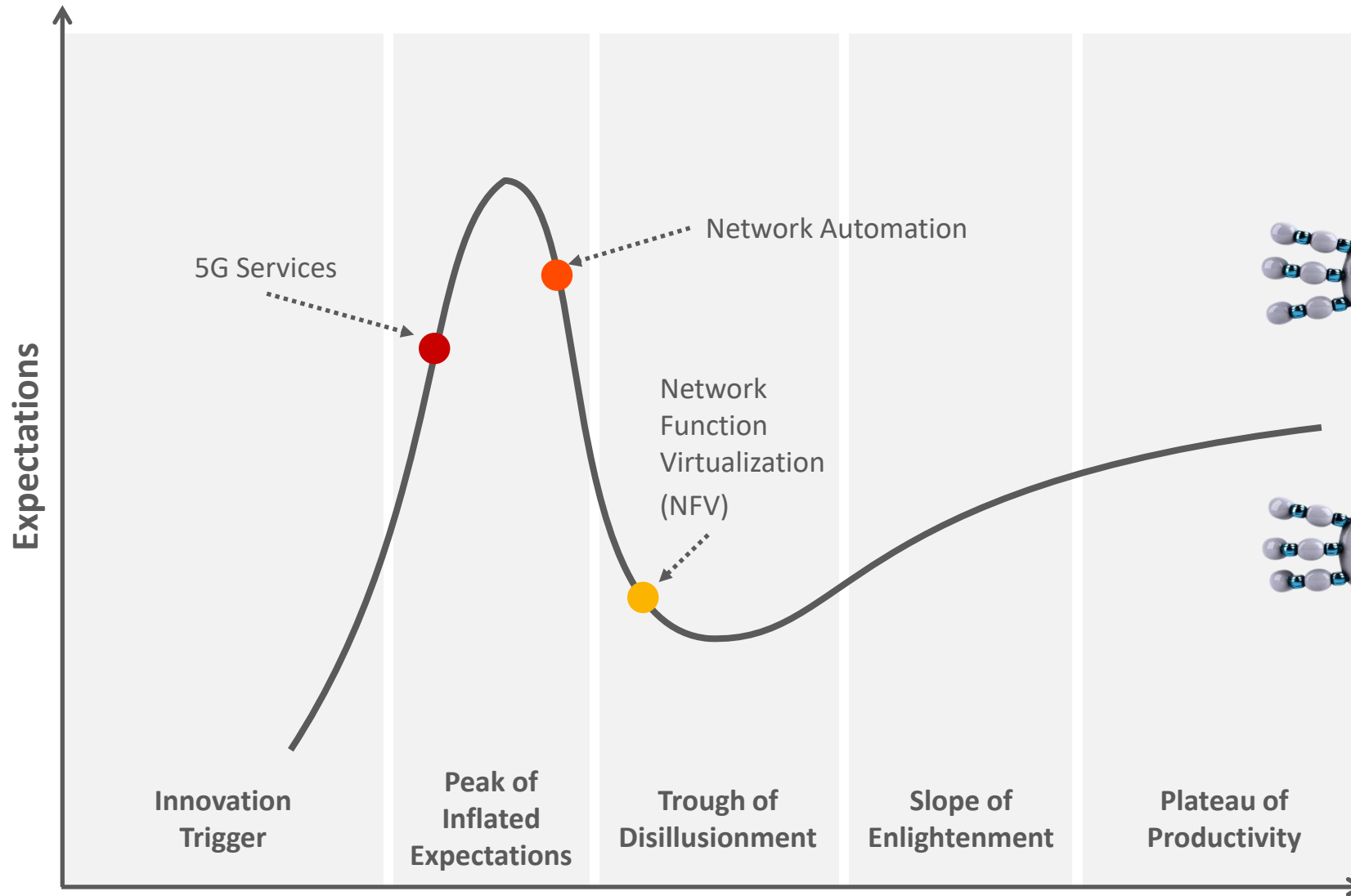

Source: Gartner

© 2020 Infinera. All rights reserved.

Stepwise Approach Toward Automation

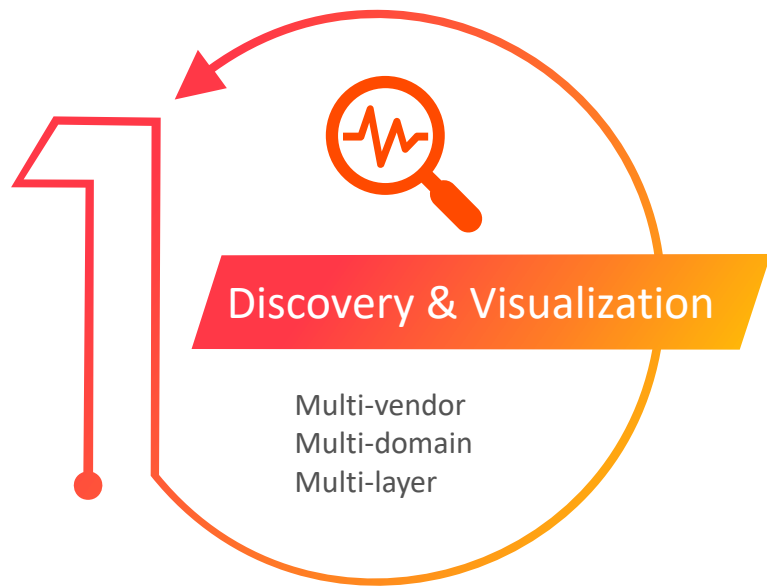

- Network discovery
- Service discovery
- Multi-layer visualization
- Synchronization view
- Network migration planning

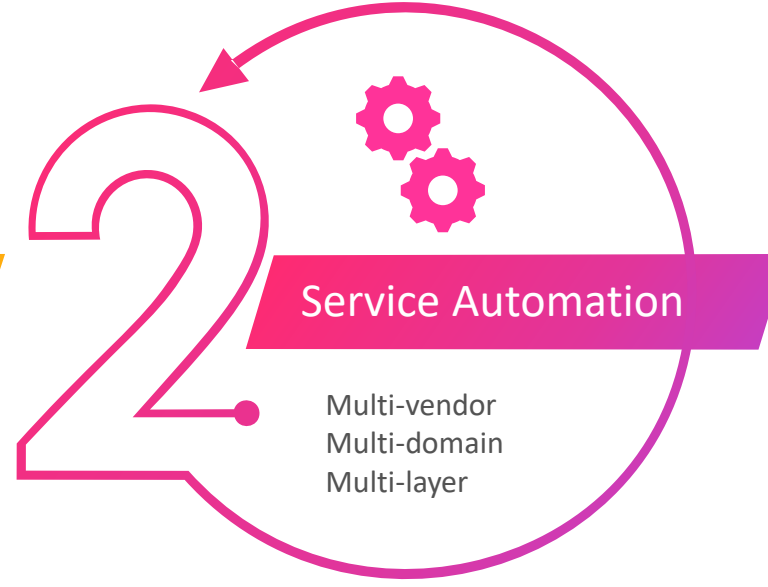

- Multi-layer service provisioning (PCE)
- Context-optimized routing
 - SRLG-aware routing
 - Optical Express
 - Latency and delay
- Workflow engines

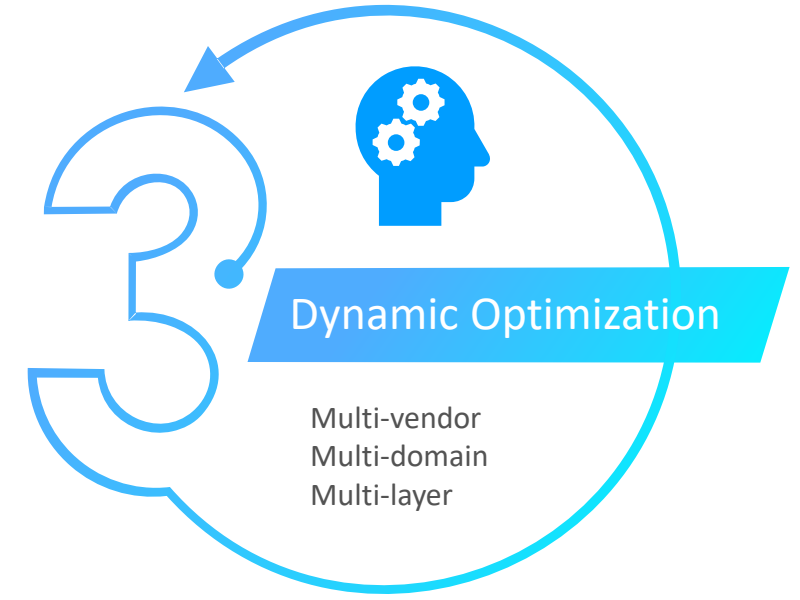

- Zero-touch deployment
- Multi-domain and multi-layer restoration
- Closed-loop automation
- Self-optimizing networks
 - e.g., latency-sensitive services
- Self-healing networks
- AI/ML

Where is the Problem?

- Monitoring
- Inventory
- Orchestration
- Network Control Plane
- Data Storage (Lake)

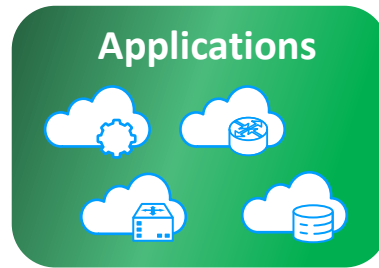

Retrieve/Store/Send Information: Vendor A, B, C, D, E

Each having

- **Different protocol**
- **Different data model**



Write adaptation for each vendor

= slow

= complicated

= dedicated experts

= silos

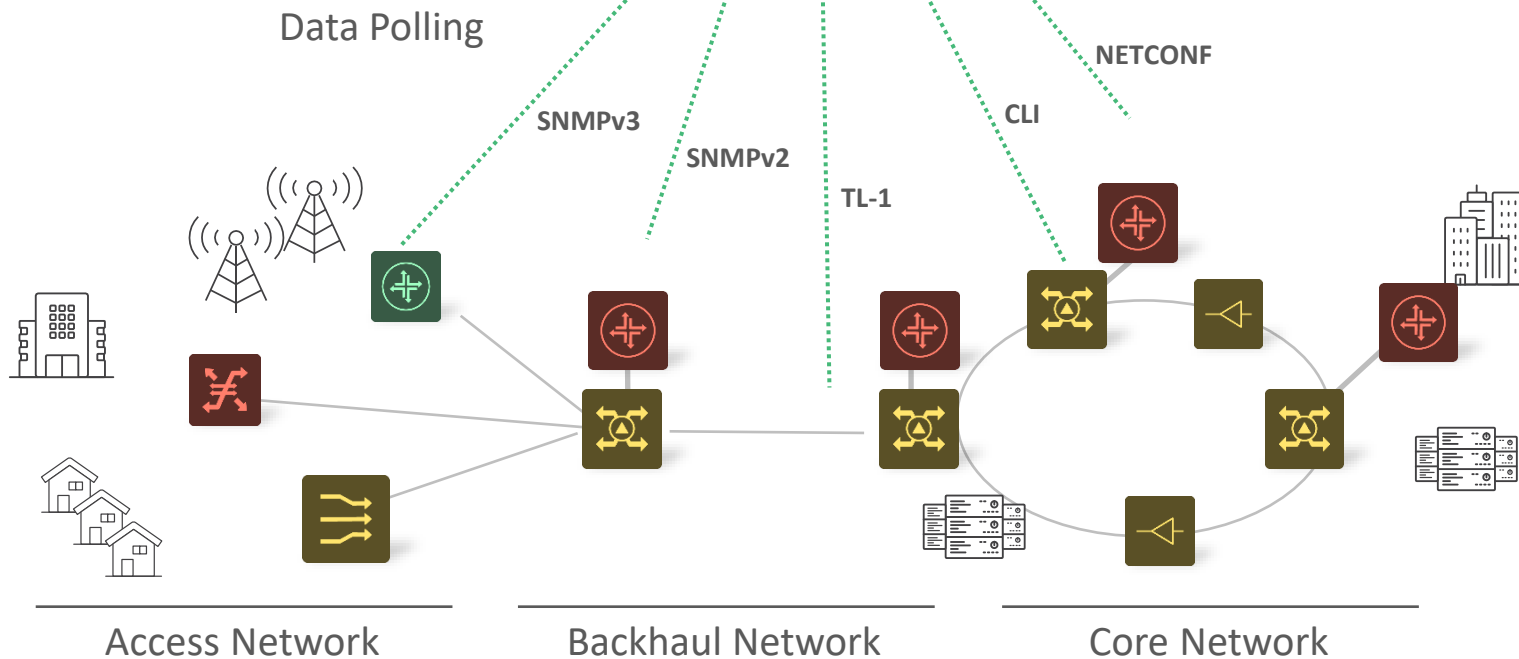



CHRIS ASPELL

Director of Innovation and Roadmap

October 2020

TRADITIONAL CABLE NETWORK

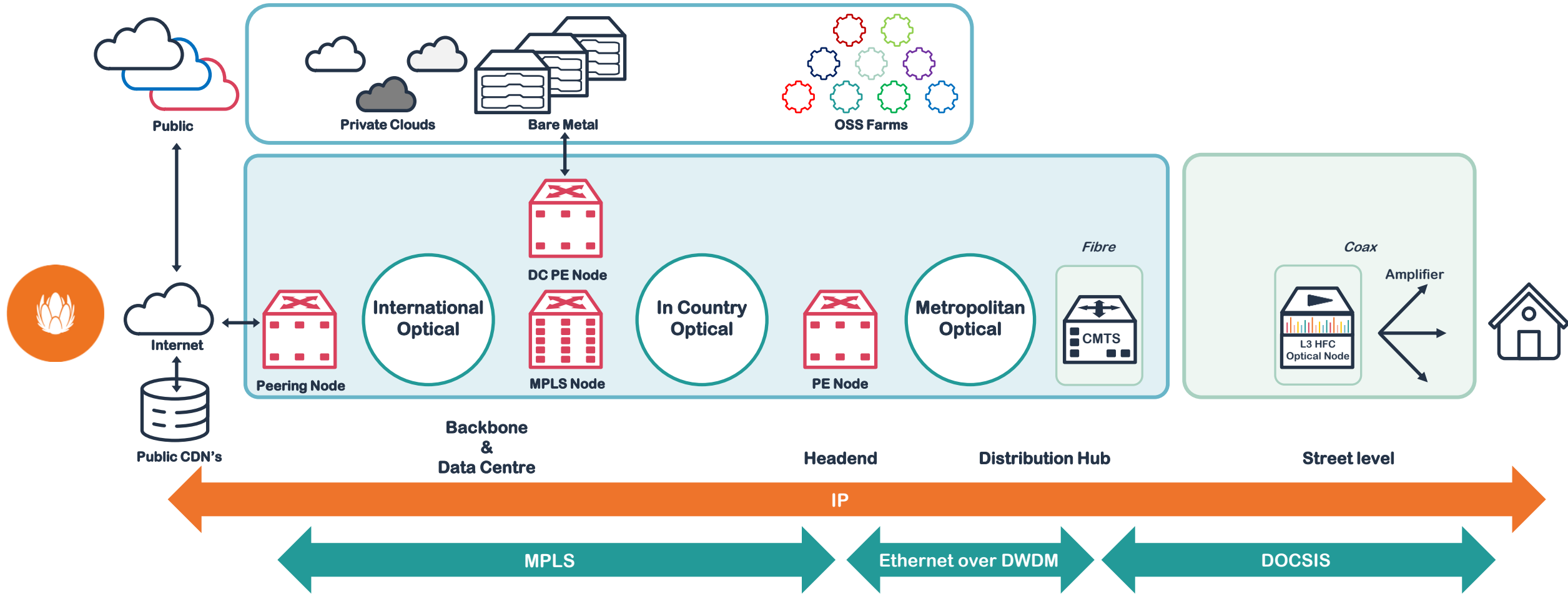

Highly manually intensive network, multiple uncoordinated compute environments, OSS per platform, per service, per Operating System

PROBLEM STATEMENT

We are on the horizon of **big changes** in how we create and manage networks as new **Open Standards** start maturing. We have **Whitebox routers, Open Optical/Open RoADM, Virtualisation and Cloudification** on our doorstep. Our **challenge** is to seamlessly **manage the transition** between these two networking worlds and keep up with capacity growth.



Our first step in the journey is Network Automation to abstract away people and process from the change whilst **increasing the rate of change, accuracy and network availability** for our customers. We will introduce Workflow, Orchestrators, Inventories, Modelling tools and a control plane.

And we need to do this within our **current budget envelopes**.

TARGET NETWORK

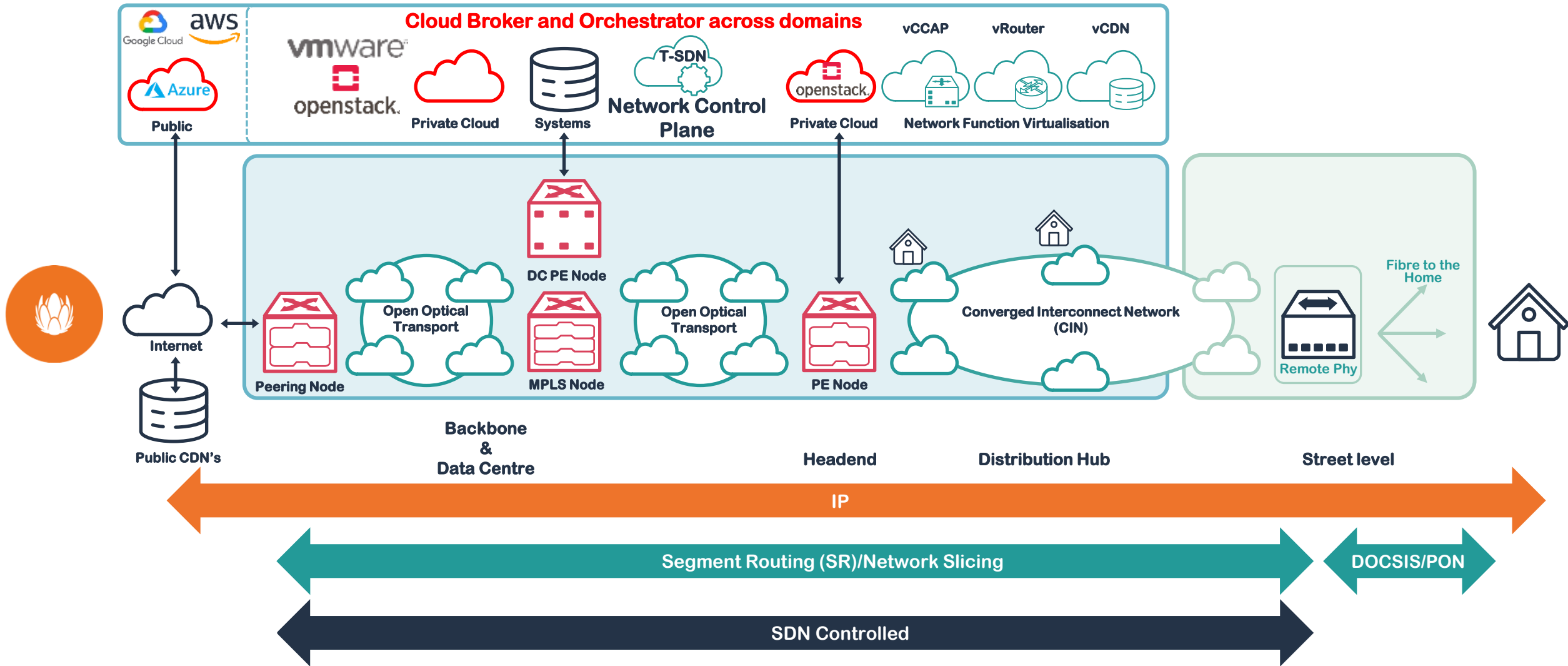

TRADITIONAL CABLE NETWORK – FIRST STEPS

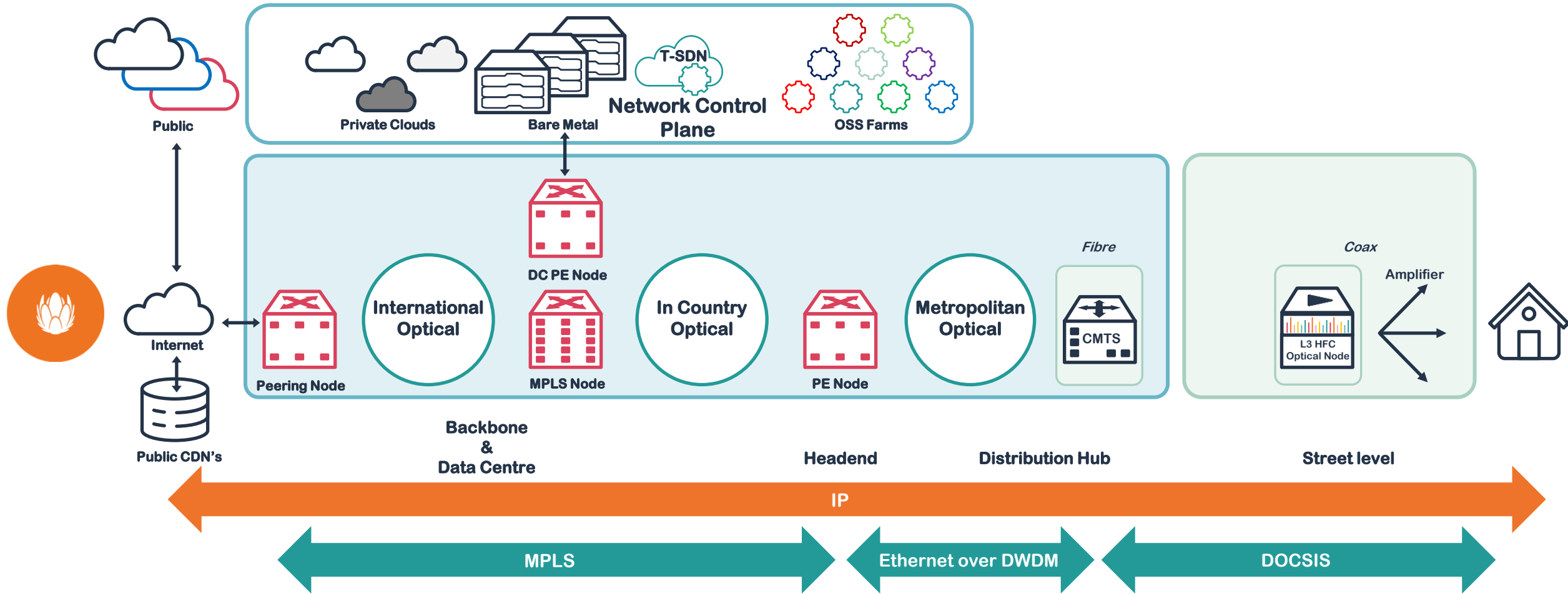

JOURNEY

B2B

Overall Reference Architecture & Scope



Management

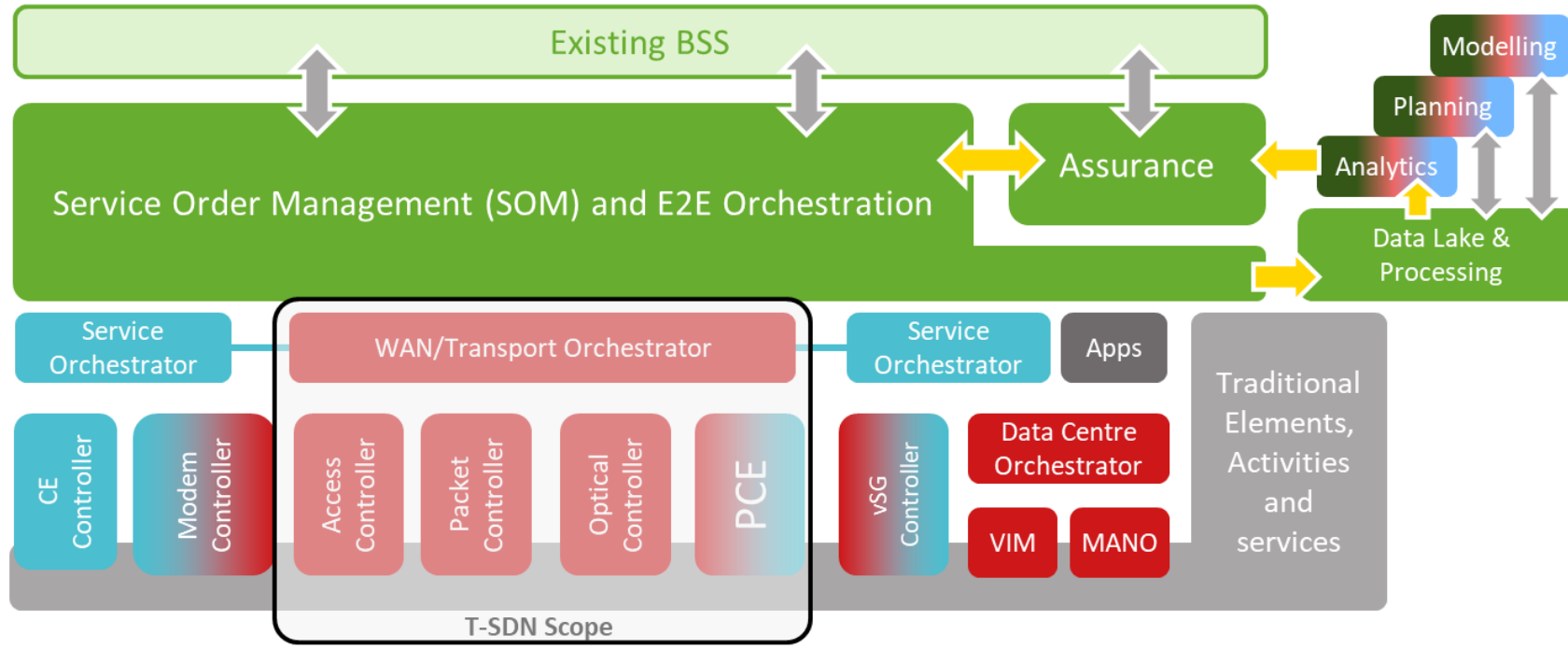

Resources

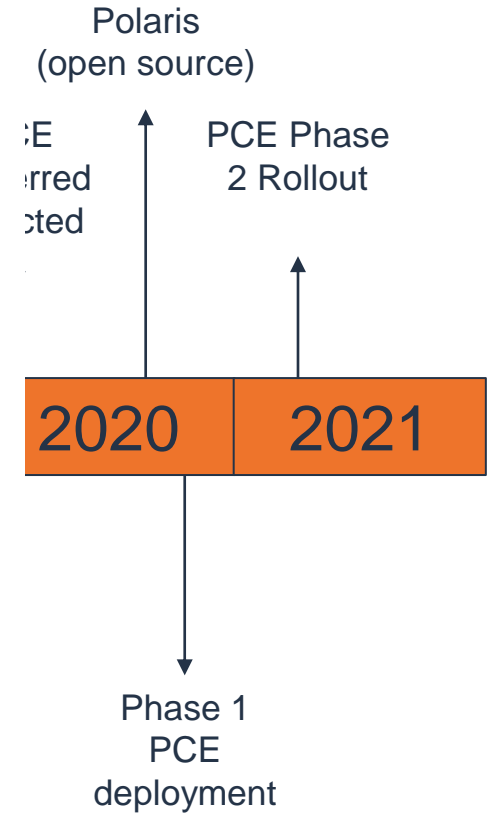



CHALLENGES

Finance

People

Processes

Vendors

Standards

Organisation

Regulatory

TARGET - FULL CLOSED LOOP NETWORK AUTOMATION

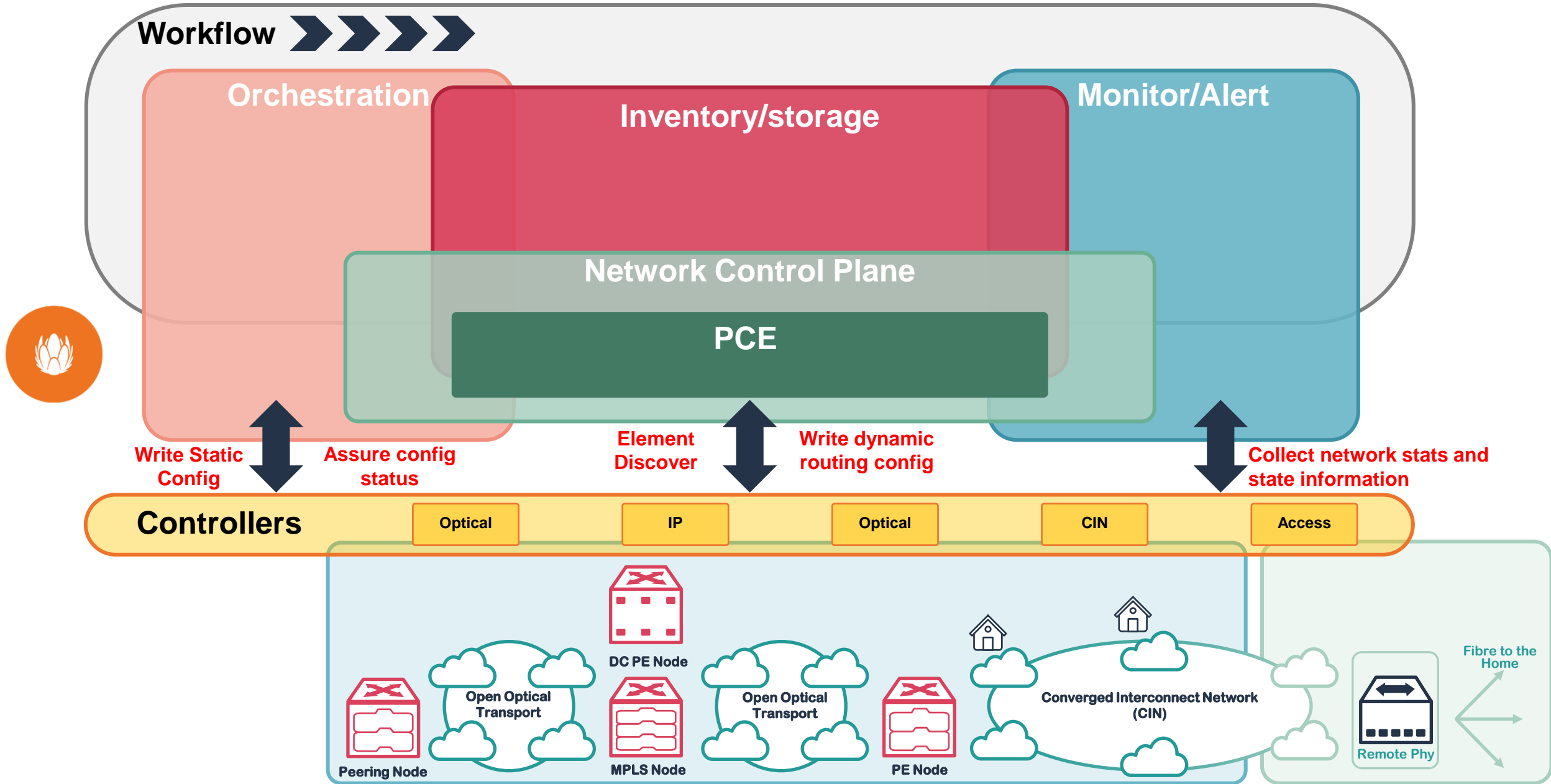

TARGET - FULL CLOSED LOOP NETWORK AUTOMATION

Workflow >>>>>

Orchestration

- Config Template Provisioning
- Config Audit
- Software Updates
- Network Provisioning

- Service Provisioning
- Initialise, Verify, Commit/Rollback
- ZTP Autoboot

Inventory/storage

- Port allocation
- Config Templates
- Hardware Inventory
- Config Backup
- Planning Records
- Workflows
- Service Catalogue
- IP Address Allocations
- Alarms
- Network Statistics

Monitor/Alert

- OSS
- Trouble Tickets
- Troubleshooting Tools
- Threshold/KPI Monitoring
- Event Monitoring
- Network Pollers

Network Control Plane

- Network Design
- AI
- Control Plane
- PCE
- Network Routing
- ML
- Alarm Event Analysis
- Network security & Policy
- Network Slicing
- Network Model
- Reporting & Analytics
- Performance Analysis

Write Static Config

Assure config status

Element Discover

Write dynamic routing config

Collect network stats and state information

Controllers

Optical

IP

Optical

CIN

Access

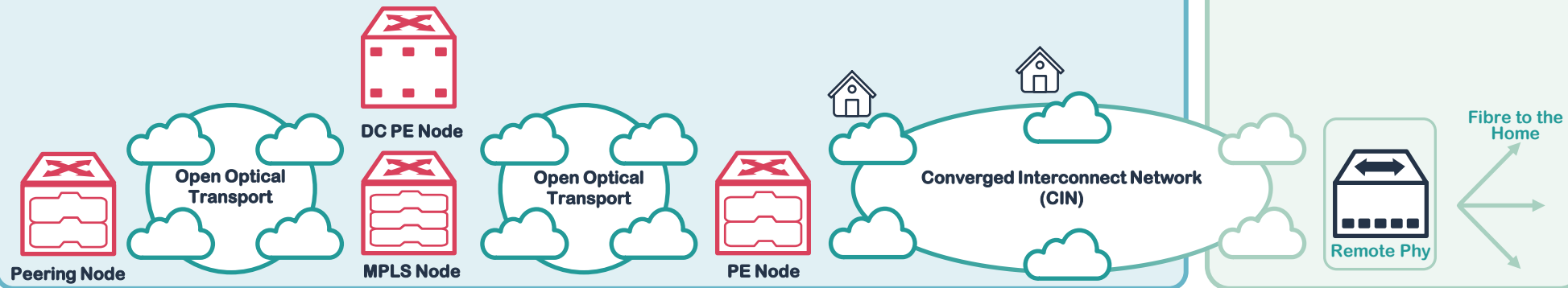

TARGET NETWORK

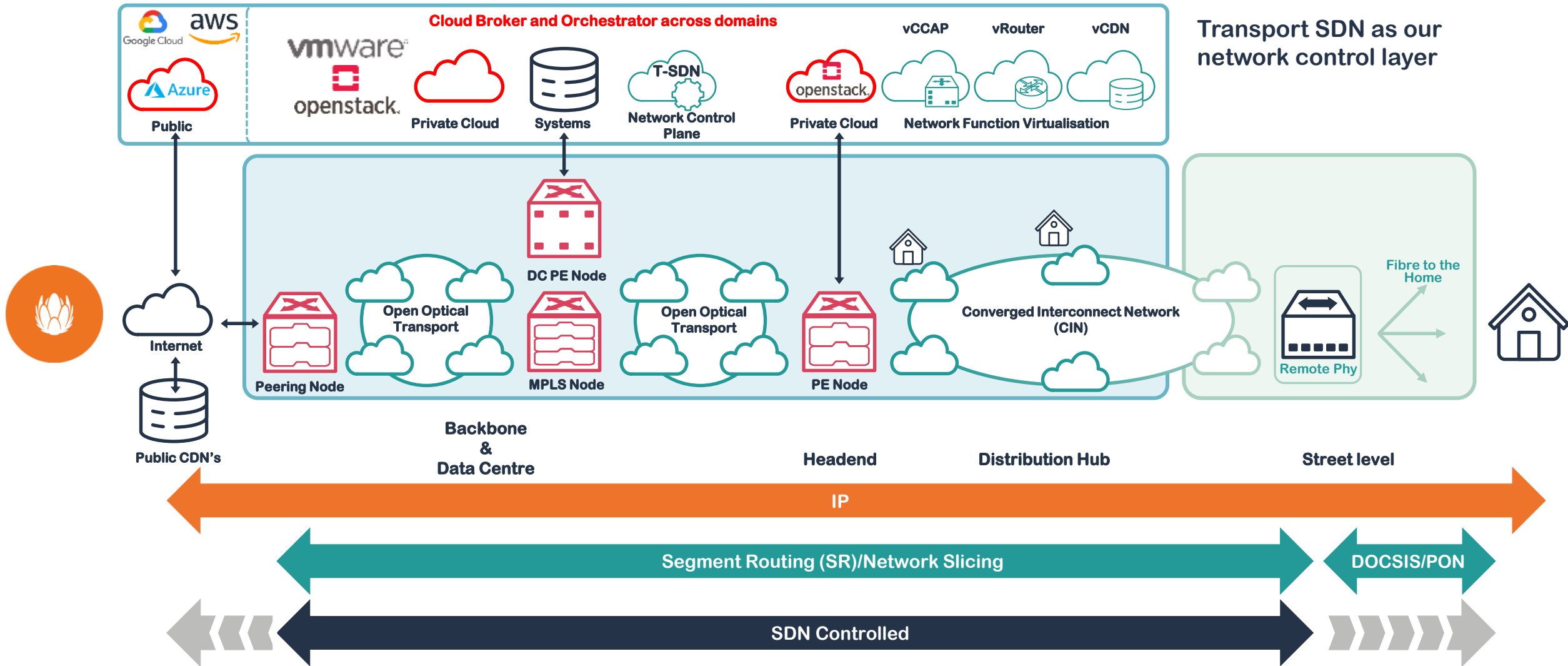

E2E SDN across all network layers to enable rapid service delivery with per customer service assurance
 Compute across all layers to allow hosting of Cloud Ready and VNF applications
 Whitebox, Open Optical, fabric based connectivity network, fully programmable



QUESTIONS?

Thank You

